



# VPV Series Purge Valves

Catalog No. VPV-2  
May 2007



## Design

D-Pro VPV Series Purge Valves are designed for manually bleeding, venting, or draining system fluids. The cap is clamped to the valve body for safety in use. The 0.063 inch (1.6 mm) diameter vent hole is constructed on the cap.

## Operation and Installation Instruction

D-Pro VPV series purge valve requires a quarter turn of cap with a wrench from finger-tight for a leak-tight seal on the first make-up.

To ensure seal to the rated pressure, snug with a wrench.

Always open the valve slowly.

These valves have no seal on cap. Therefore media may flow through the cap thread when the valves are opened. Operating personnel should take suitable measures to be protected from system fluids.

## Technical Data

Valve Material	Pressure Rating @ 100 °F (38 °C)		Temperature Range	
	psig	bar	°F	°C
SS316	4000	275	-65 ~ 600	-54 ~ 315
Brass	3000	206	-65 ~ 400	-54 ~ 204

## Materials of Construction

Components	VALVE BODY MATERIALS	
	SS316	Brass
	Grade / ASTM Specification	
Cap	SS316/A479 or A276	Brass/B16
Body		
Ball	SS316/A276	
Spring	SS302/A313	

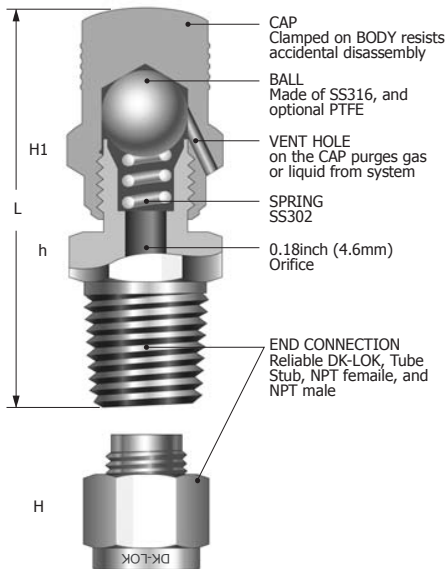

## Ordering Information and Table of Dimensions

Basic Ordering Number	End Connection	L - closed		h	H	H1	
		inch	mm	Hex	Hex	Hex	
VPV-	F-2N-	1/8" Female NPT	1.5	38.1	9/16	-	5/8
	F-4N-	1/4" Female NPT	1.69	42.9	3/4	-	
	F-6N-	3/8" Female NPT	1.75	44.5	7/8	-	
	F-8N-	1/2" Female NPT	1.92	48.8	1-1/16	-	
	M-2N-	1/8" Male NPT	1.56	39.6	1/2	-	
	M-4N-	1/4" Male NPT	1.75	44.5	9/16	-	
	M-6N-	3/8" Male NPT	1.78	45.2	11/16	-	
	M-8N-	1/2" Male NPT	2.03	51.6	7/8	-	
	D-2T-	1/8" DK-LOK	1.78	45.2	1/2	7/16	
	D-4T-	1/4" DK-LOK	1.88	47.8	1/2	9/16	
	D-6T-	3/8" DK-LOK	1.97	50.0	5/8	11/16	
	D-8T-	1/2" DK-LOK	2.13	54.1	13/16	7/8	
	D-6M-	6mm DK-LOK	1.88	47.8	14mm	9/16	
	D-8M-	8mm DK-LOK	1.94	49.3	15mm	5/8	
	T-4T-	6mm Tube Stub	1.81	46.0	1/2	-	
	T-6T-	3/8" Tube Stub	1.88	47.8	1/2	-	
T-8T-	1/2" Tube Stub	2.09	53.1	9/16	-		

## Options and How to order

Optional PTFE ball is available. Valve with Teflon ball does not require wrench but only finger-tight for leak-tight shut-off.

- Removable cap for PTFE ball replacement
- Pressure rating : 200 psig @ 100 °F (13.7 bar @ 37 °C)
- Maximum Temperature : 350 °F (176 °C)

To order, add the valve body material as a suffix to the basic ordering number. S: Stainless, B: Brass. Example: VPV-M-2N-S

To order PTFE ball valve, add PE to the basic ordering number. Example: VPV-M-4N-PE-B

## Factory Test

Every valve is tested with the nitrogen @ 68 bar (1000 psi) for leakage at the seat to a maximum allowable leak rate of 0.1 scc/min.

The valve with PTFE ball is tested at 0.69 bar (10 psi) for leakage at the seat to a maximum allowance leak rate of 0.1 scc/min.

**IDK-LOK**<sup>®</sup>  
Fittings & Valves  
www.dklok.com

**IDK Tech Corporation**  
Mailing Address  
826, Naesam-Ri, Juchon-Myeon, Gimhae-City,  
Gyeong Nam, Korea 621-841

DK TECH contact information  
Tel. (82) 55-338-0114  
Fax (82) 55-338-6745  
E-mail: sales@dklok.com

For International customers  
Tel. (82) 55-338-0031/2  
Fax (82) 55-338-6746  
E-mail: dklok@dklok.com